



Rewarding Learning

ADVANCED
General Certificate of Education
2018

Centre Number

--	--	--	--	--

Candidate Number

--	--	--	--

Technology and Design

Assessment Unit A2 1

assessing

Systems and Control or
Product Design

MV18

[ATE11]

FRIDAY 8 JUNE, MORNING

Time

2 hours, plus your additional time allowance.

Instructions to Candidates

Write your Centre Number and Candidate Number in the spaces provided at the top of this page and on the A3 pro forma answer pages provided.

Answer **both** questions in **either** Section A, B or C.

Answers to Questions **3(c)**, **3(d)(i) and (ii)**, **4(b)**, **4(d)(i) and (ii)**, **5(g)**, and **6(h)(i) and (ii)** should be made on the A3 pro forma answer pages provided.

At the conclusion of the examination, attach the A3 pro forma answer pages securely to this paper with the treasury tag supplied.

Information for Candidates

The total mark for this paper is 80.

Quality of written communication will be assessed in Questions **1(d)**, **4(c)** and **5(f)**.

Figures in brackets printed at the end of each question indicate the marks awarded to each question or part question.

BLANK PAGE

(Questions start overleaf)

Section A

Electronic and Microelectronic Control Systems

Answer **both** questions in this section

- 1 (a) A voltage divider circuit with a thermistor and fixed resistor is shown in **Fig. 1**. The resistance/temperature characteristic for the thermistor is also shown.

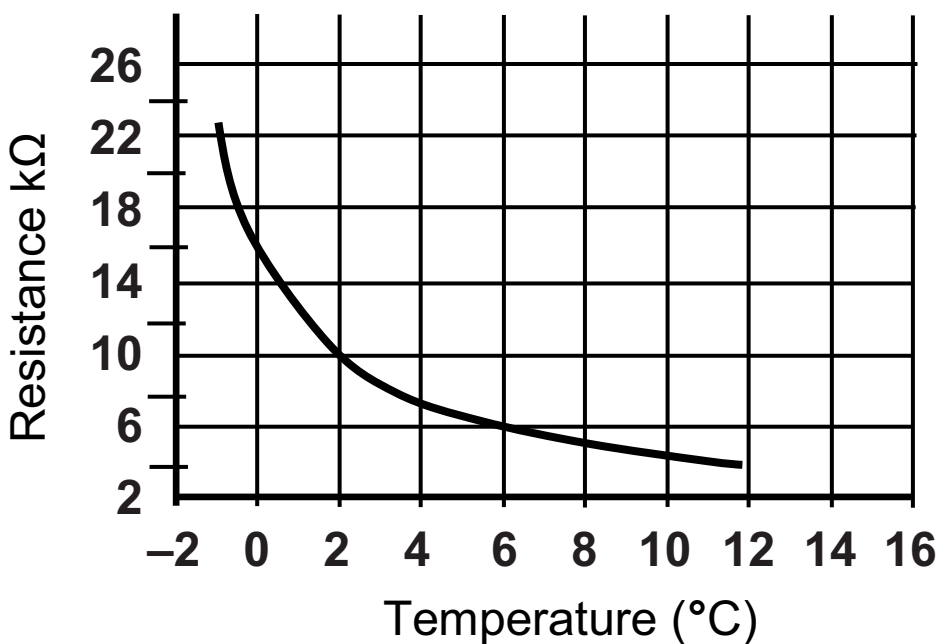
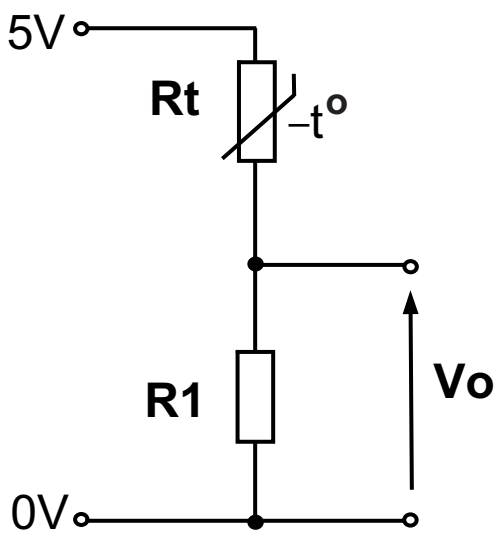
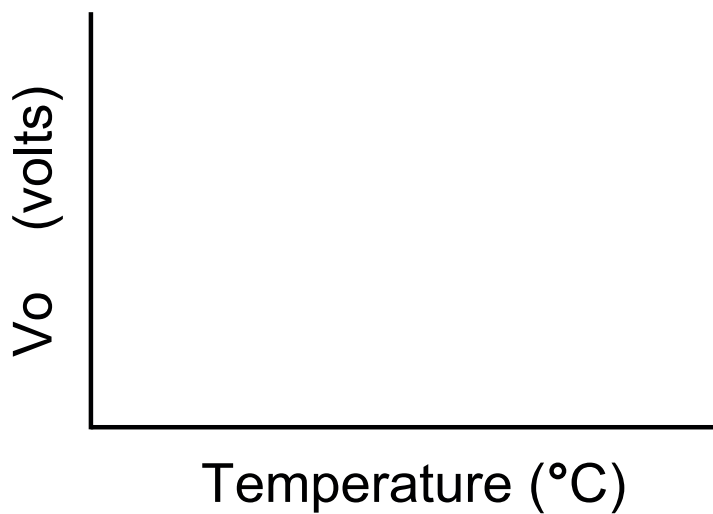

Fig. 1

- (i) With reference to the resistance/temperature characteristic and voltage divider arrangement in **Fig. 1** explain the relationship between the resistance of thermistor R_t and the voltage V_o . [2 marks]

- (ii) Sketch a graph on the axes below showing V_o against temperature for the voltage divider shown in **Fig. 1**. [2 marks]



(iii) If the air temperature around the thermistor shown in **Fig. 1** is 2°C calculate the corresponding voltage for V_o if R_1 has a value of $10\text{k}\Omega$. [2 marks]

$V_o =$ _____

(iv) The resistor R_1 shown in **Fig. 1** is to be replaced with a variable type resistor.
State **one** main advantage of doing this. [1 mark]

(b) The output V_o from the voltage divider shown in **Fig. 1** is connected to the input of an analogue to digital converter (ADC) which is shown in **Fig. 2**.

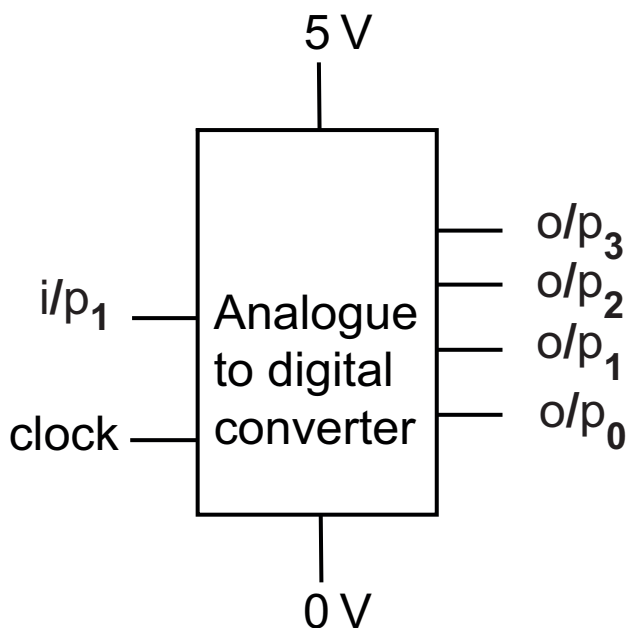

Fig. 2

- (i) The voltage to the analogue input i/p_1 to the ADC shown in **Fig. 2** can range from 0V to 5V and the corresponding binary output ($o/p_0 - o/p_3$) range is 0000 to 1111. Calculate the 4 bit binary equivalent value that corresponds to an input voltage of 2V. [2 marks]

4 bit binary equivalent _ _ _ _

- (ii) The clock input on the ADC shown in **Fig. 2** is used to control the frequency of conversion. Explain with the aid of an annotated circuit diagram a method of providing a 5 volt clock pulse with a frequency of 10 Hertz. [4 marks]

(c) The binary outputs from the ADC in **Fig. 2** are connected to the inputs of a 7 segment decoder and LED 7 segment display shown in **Fig. 3**.

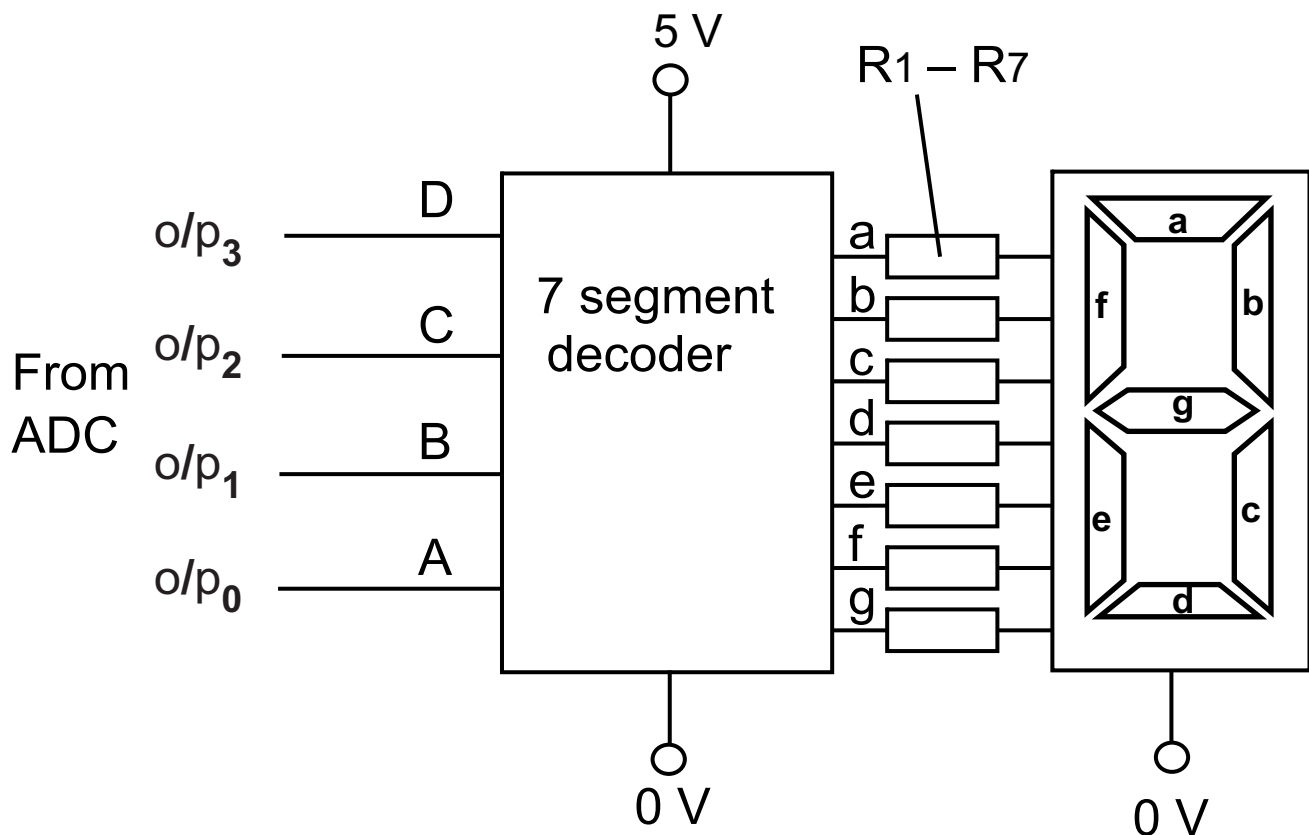

Fig. 3

(i) Complete the logic truth table below for the 7 segment decoder in **Fig. 3** for the missing input D (where A is the least significant bit) and the missing output g for the displayed numeral '5'. [2 marks]

A	B	C	D	a	b	c	d	e	f	g
1	0	1		1	0	1	1	0	1	

- (ii) The LED 7 segment display shown in **Fig. 3** is common cathode. Briefly explain what is meant by the term common cathode. [2 marks]
-
-

- (iii) Each segment of the LED 7 segment display in **Fig. 3** contains a single LED that operates at a forward voltage of 2.3V and a maximum current of 10mA. Calculate the value for the protective resistor required for one segment if the output voltage from the decoder is 5 V. [2 marks]

Resistor value = _____

- (iv) Determine the total power dissipated by the calculated protective resistor when one segment is illuminated. [2 marks]

Power dissipated = _____

(e) The voltage divider in **Fig. 1**, and the 7 segment decoder and display in **Fig. 3** are to be used as the basis of a PIC based prototype system to control the temperature in a warehouse refrigerator. The PIC has an on board ADC with the same resolution as the ADC shown in **Fig. 2**. The temperature can be set to one of 3 preset values, (which are displayed) using a rotary switch as shown in **Fig. 4**. Once the temperature has been selected the system will check the temperature and turn on a refrigerator pump, which is driven by a 24 volt DC motor.

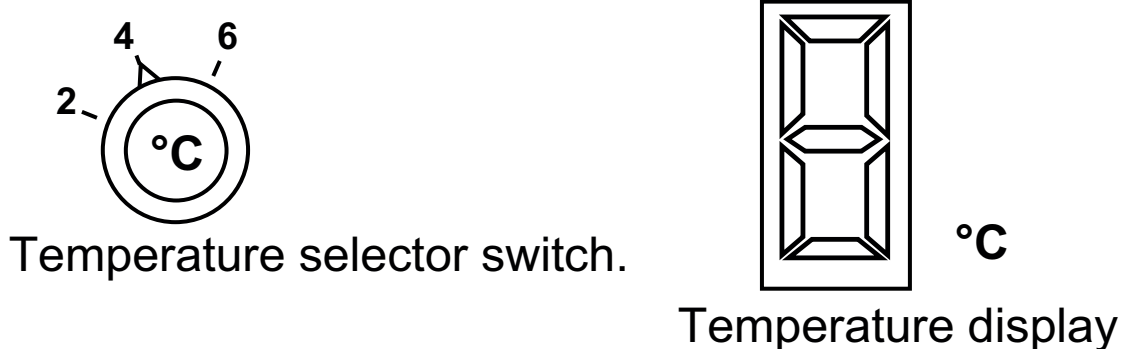

Fig. 4

Draw an annotated circuit diagram with associated flow chart program (on the following pages) to achieve the following:

- Allow the user to select one of three temperatures for the refrigerator.
- Display the selected temperature on the 7 segment display.
- Switch on the refrigerator pump for a period of 5 seconds if the temperature rises above the selected temperature.
- Keep switching the refrigerator pump on until the temperature drops to the selected temperature before continuing to check the selector switch.

[10 marks]

Answer Page Question No. 1(e)

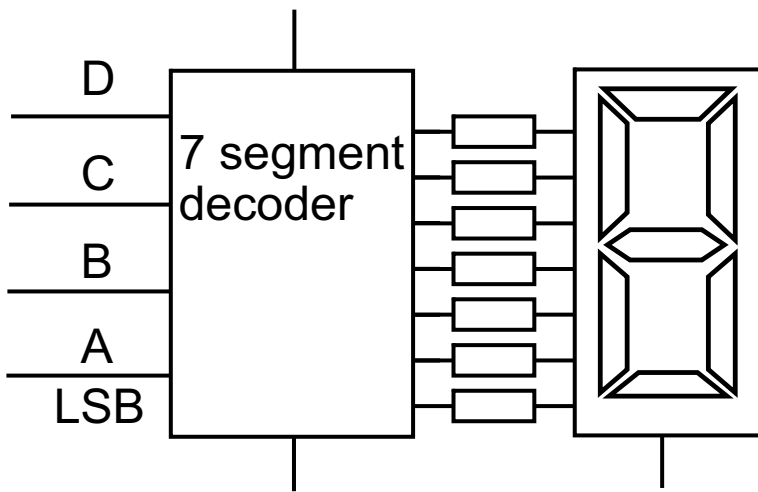

Answer Page Question No. 1(e)

- 2 (a) A reflective optical switch is shown in **Fig. 5**. The pin connections for the emitter (LED) and receiver (phototransistor) are labelled. The optical switch is positioned above a surface which has both a light and a dark coloured surface.

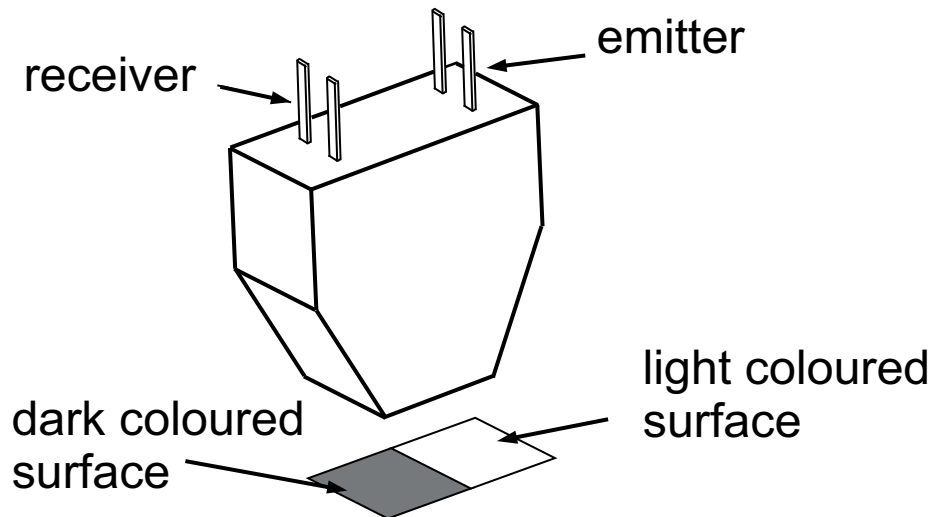

Fig. 5

- (i) Draw the circuit symbols for the emitter and receiver in the reflective optical switch shown in **Fig. 5**.
[2 marks]

(ii) The emitter LED in the reflective optical switch shown in **Fig. 5** emits infrared light. Explain **one** main advantage of using infrared light in optical switch applications. [2 marks]

(iii) Draw and label a circuit diagram showing how the emitter and phototransistor from the optical switch in **Fig. 5** could be utilised to produce logic 'high' voltage when positioned above a light coloured surface and a logic 'low' when positioned above a dark coloured surface. [3 marks]

(b) The front panel of an electronic weather vane display system is shown in **Fig. 6**. The wind direction LEDs on the front panel shown are to be illuminated by means of a logic circuit. The inputs to the circuit are reflective optical switches of the type shown in **Fig. 5**. The optical switches are labelled A and B and are positioned over an encoded disc which has light and dark coloured areas as shown. The disc itself will be turned by a weather vane and the appropriate direction LEDs will then be illuminated.

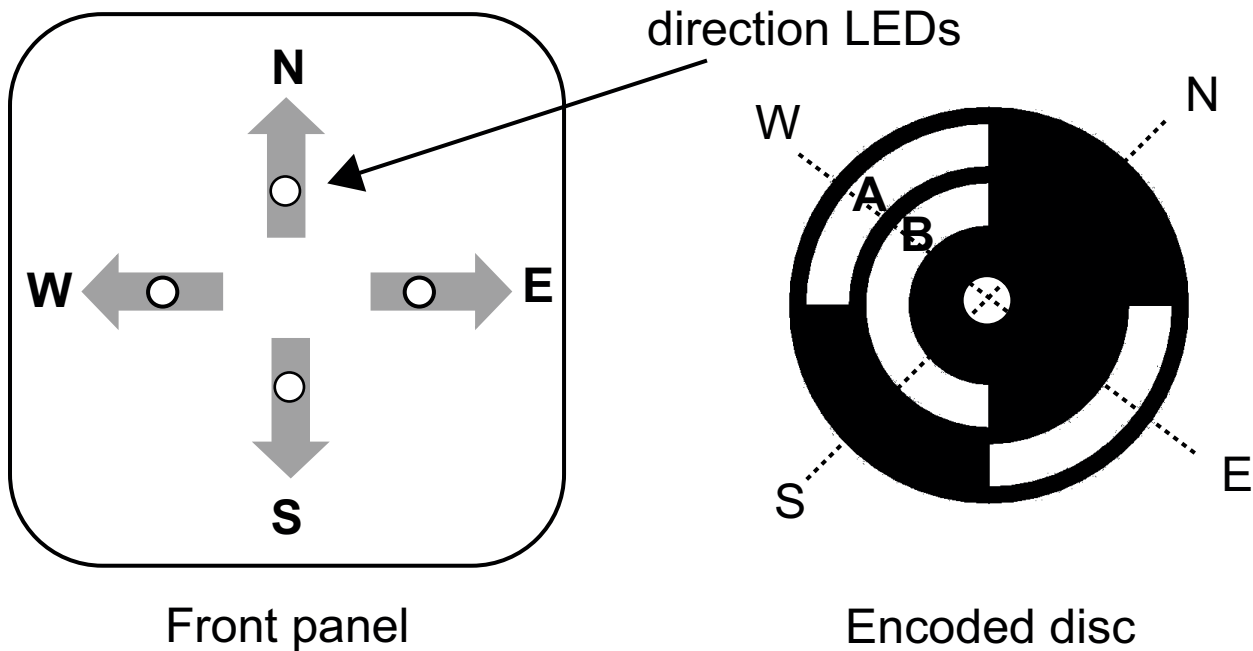

Fig. 6

- (i) Complete the truth table below showing the logic signals from the sensors for each of the wind directions as the disc in **Fig. 6** rotates in a clockwise direction. Assume that a logic 1 is produced when the optical switch is positioned over a light coloured surface and a logic 0 when positioned above a dark coloured surface. [4 marks]

Dir.	A	B
W		
S		
E		
N		

- (ii) Write logic expressions for each of the two outputs, N and S [2 marks]

N = _____

S = _____

- (iii) Draw a single logic circuit to control the two output LEDs N and S. [2 marks]

(c) The complete logic circuit used to control the four direction LEDs in **Fig. 6** is to be replaced by a PIC based circuit and flowchart. The inputs and outputs for the PIC are labelled as follows:

Inputs	Optical switch A	D1
	Optical switch B	D2
Outputs	North LED	Q1
	East LED	Q2
	South LED	Q3
	West LED	Q4

(i) Explain **one** main advantage (other than cost) of using a PIC based circuit instead of a logic circuit to control the direction LEDs as shown in **Fig. 6**.
[2 marks]

(ii) Write a flowchart program (using the minimum number of commands) to check the wind direction every 2 seconds and illuminate the appropriate LED output. [5 marks]

(d) The wind direction system in **Fig. 6** is to be developed in order to provide a wider range of directions. The proposed front panel is shown in **Fig. 7** along with the incomplete encoded disk to allow eight directions to be shown using three reflective optoswitches A, B, and additional switch C. The encoded disk utilises Gray Code.

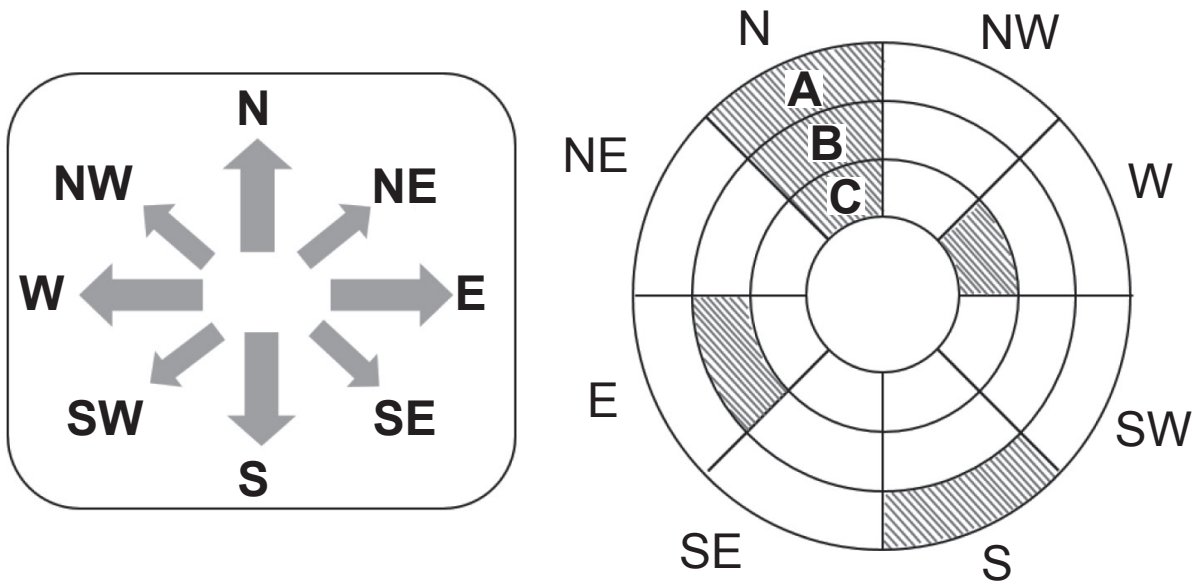

Fig. 7

(i) State the advantage of utilising Gray Code for the encoded disk. [1 mark]

(ii) Complete the Gray Code disk in **Fig. 7** by adding shading to the NW, SW, SE and NE sectors of the disc to enable all eight directions to be detected and displayed. Assume a shaded segment will produce a logic '0' and that the disk rotates clockwise. [4 marks]

(e) A wind speed indicator is to be added to the wind direction system in **Fig. 7**. It has been proposed that a strain gauge could be used to detect the deflection of a flexible stem that will bend according to wind speed. **Fig. 8** shows how a strain gauge is fixed to the flexible stem which in turn will be deflected by the force of the wind acting on a rigid paddle. The wind speed can then be displayed on an eight bar LED bar array display. The strain gauge is shown in **Fig. 8** and has a resistance of $120\ \Omega$. Under test conditions the resistance of the strain gauge increased by 1.25% at the maximum wind speed.

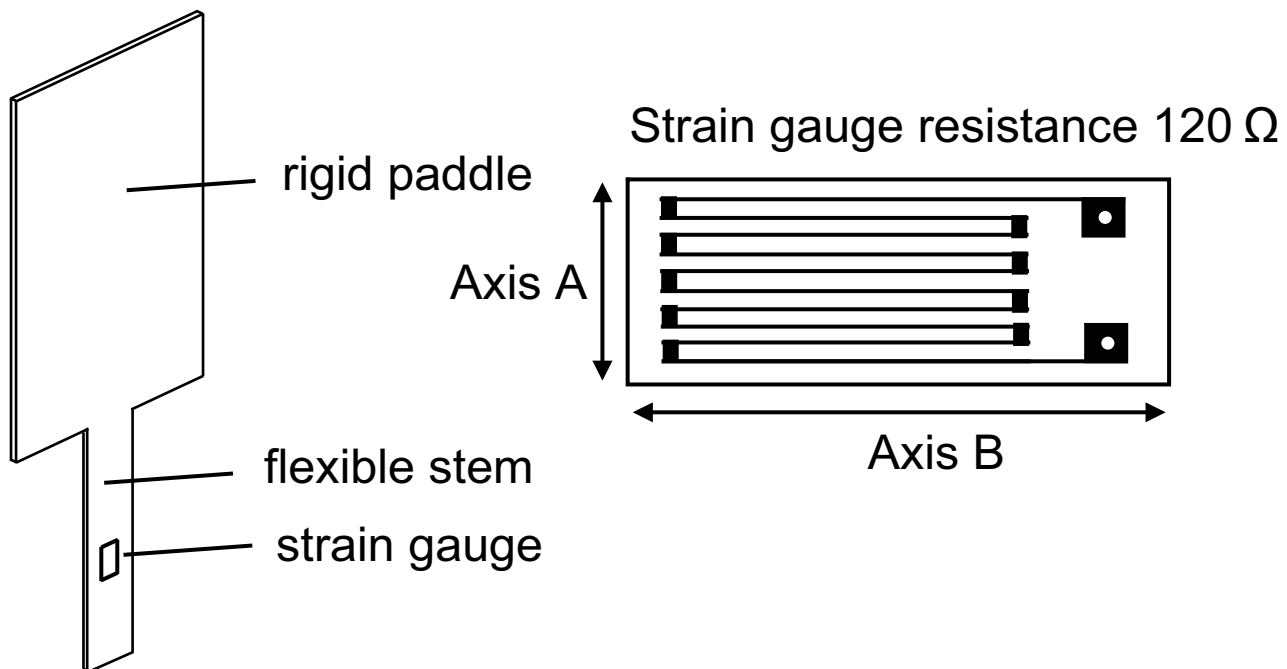

Fig. 8

- (i) Calculate the resistance of the strain gauge shown in **Fig. 8** when experiencing maximum wind speed. [3 marks]

Resistance of strain gauge _____

- (ii) Using annotated electronic circuit diagrams on the page opposite, design a system based on an op-amp and bar array display driver that will:
- detect the bending movement of the flexible stem compensating for any temperature changes.
 - amplify the small change in resistance of the strain gauge and represent the wind speed on an eight bar LED bar array display.
 - illuminate all eight bars of the bar display when the strain gauge is experiencing the maximum wind speed as tested.
 - ensure all bars in the bar array should be off when there is no wind.
 - operate with a power supply of +6 volts and –6 volts.

Your answer should specify suitable component values where appropriate and you may assume that the bar array display driver input voltage range is 0V–6V. [10 marks]

Answer Page Question No. 2(e)(ii)

Section B

Mechanical and Pneumatic Control Systems

Answer **both** questions in this section.

- 3 (a) (i) Outline **two** main procedures used to minimise the risks associated with pneumatic systems.
[1 mark for each]



Fig. 9

- (ii) The mobile crane shown in **Fig. 9** on page 26 has a winch for lifting loads. The winch hook pulls a load with a mass of 2500 kg up a vertical height and gains 220950 J in potential energy before stopping. Calculate the vertical height the load is lifted. Assume $g = 9.82 \text{ m/s}^2$ and ignore friction. [3 marks]

Vertical Height = _____

- (iii) Calculate the minimum power required from the winch output shaft to lift the hook 2 metres in 30 seconds if the gravitational force on the hook is 33 N. Assume a 25% loss of power due to friction. [3 marks]

Minimum Power = _____

- (iv)** The output torque from the main transmission shaft of the mobile crane engine is 130Nm. Assuming no power loss, calculate the power from the main transmission shaft of the engine if it rotates at 200 rev/min. [3 marks]

Power = _____

- (b) (i)** Ball and socket joints are used on the steering mechanism of the mobile crane. With the use of an annotated sketch outline the main features of a ball and socket joint. [3 marks]

(ii) Garter seals are used on the drive shaft of the gearbox for the mobile crane shown in **Fig. 9**. Using an annotated sketch outline the main features of a garter seal and explain why it would be selected in preference to an O-ring on the drive shaft of the gearbox. [3 marks]

Explanation: [2 marks]

(c) Within a manufacturing plant a range of pneumatic systems is used. Complete the following sequence on pro forma (answer number **3(c)**) using the minimum number of groups. Some of the piping has been completed on the pro forma to assist you. The sequence follows these stages:

- The sequence begins by momentarily closing the guard for either START 3/2 Valve A or START 3/2 Valve B.
- Cylinders A1 and A2 go negative. When Cylinder A2 is in the negative position it is detected by the roller trip 3/2 valve.
- Cylinder B then goes positive. When Cylinder B is in the positive position it is detected by the 3/2 valve and sends Cylinder B negative.
- Following detection by the 3/2 valve Cylinder C then goes negative. Following detection by the 3/2 valve Cylinder C then goes positive. When Cylinder C is in the positive position it is detected by the air bleed and enables Cylinder D to go positive.
- Following detection by the 3/2 valve Cylinder D goes negative.
- Following detection of Cylinder D in the negative position Cylinders A1 and A2 go positive.
- Following detection of Cylinder A1 in the positive position a time delay is created before the sequence restarts.

[11 marks]

(d) On the pro formas provided (answer numbers **3(d)(i)** and **3(d)(ii)**) design, draw and annotate an appropriate system which would achieve the following requirements:

- (i)** A means of enabling the grips of the robotic arm to close following activation of micro-switch A and open via activation of micro-switch B. A suitable mechanism must be added to the double acting cylinder to enable the grips to open on the positive stroke of the double acting cylinder and close on the negative stroke. [5 marks]

- (ii)** A means of enabling the platform to be moved up and down using an appropriate mechanism. The operator will need a high level of positional control to ensure that the platform can stop at a set height. The double acting cylinder is controlled by the operator using the push-button 3/2 valves A and B. Please indicate all suitable connections from the double acting cylinder to the linkage. [5 marks]

- 4 (a) (i) Pneumatics and hydraulics are two common methods of control used in industrial applications. With reference to a double acting cylinder compare in detail the output force if activated by pneumatics to that activated by hydraulics.

Force Comparison [2 marks]

Also, with reference to a double acting cylinder compare in detail the speed if activated by pneumatics to that activated by hydraulics.

Speed Comparison [2 marks]

- (ii) Vacuum lifting cups are used on a range of pneumatic systems. Explain the main purpose of a vacuum lifting cup and give **one** suitable application.

Explanation: [2 marks]

Application: [1 mark]

- (iii) Diaphragm clutches are used in a range of vehicles. Using an annotated sketch outline the main features of a diaphragm clutch. [3 marks]

- (iv) With reference to the data in **Fig. 10** calculate the air consumption on the negative stroke in cm^3 for the cylinder shown. Show your working out clearly. Assume $\pi = 3.14$. [3 marks]

$D = 7 \text{ cm}$
 $S = 60 \text{ cm}$
 $d = 2 \text{ cm}$
 Working pressure = 3.5 Bar

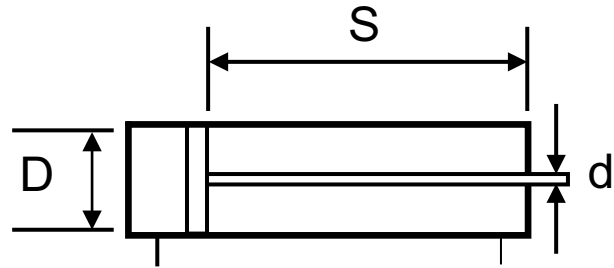

Fig. 10

Air Consumption = _____

- (v) The double acting cylinder can exert a force of 220 N and has a stroke length of 60 cm. Calculate the useful work done by the cylinder if the 220 N force loses 30% through inefficiency. Show your working out clearly. [2 marks]

Work done: _____

(b) **Fig. 11** shows a performance/displacement diagram. On pro forma (answer number **4(b)**) using an appropriate drawing technique, construct a cam profile which would accurately follow the performance/displacement diagram. The minimum cam diameter is 50 mm. The follower is a roller follower with a diameter of 10 mm and the cam rotates in an anticlockwise direction. [6 marks]

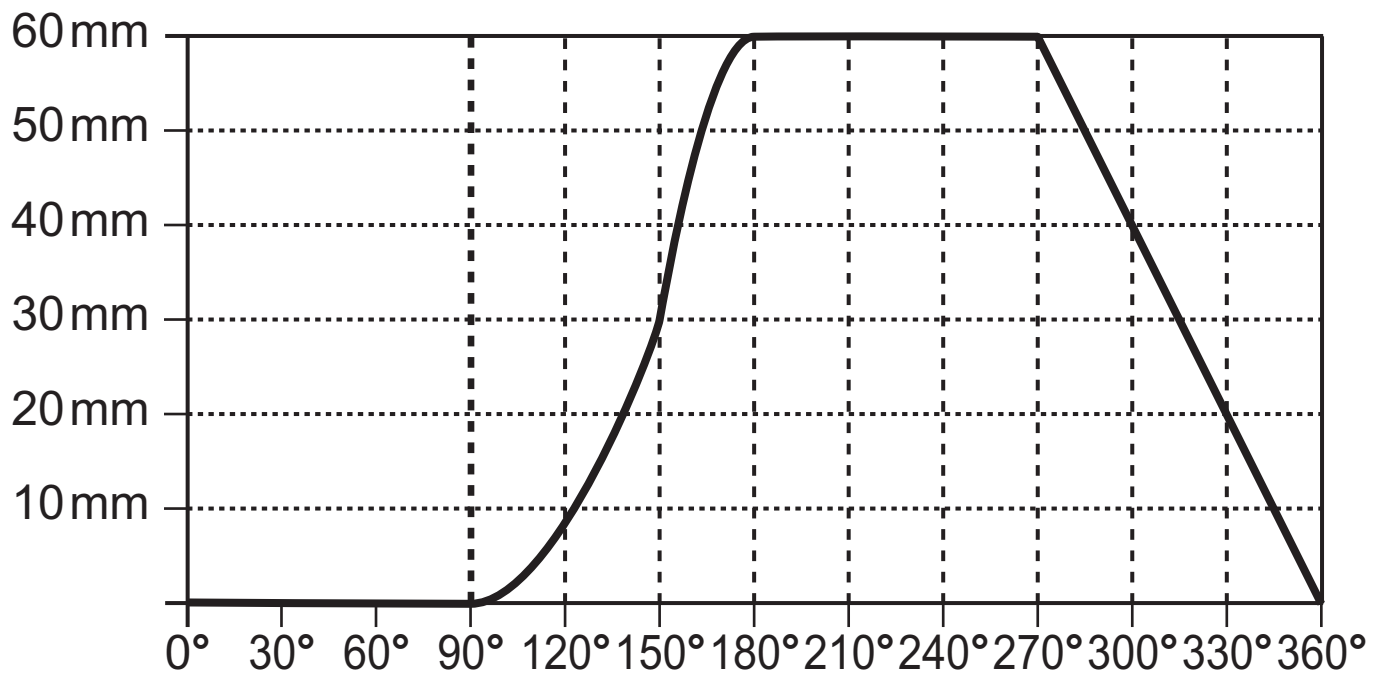

Fig. 11

(c) Brakes play a vital role in a range of mechanical systems. Discuss **three** characteristics of drum brakes and **two** characteristics of disc brakes. Please exclude cost and availability from your answer. [9 marks]

Quality of written communication will be assessed in this question.

(d) Mechanisms are required to be used on a range of applications to include car park barriers and crane stabilisers.

(i) On pro forma answer number **4(d)(i)** design, draw and annotate an appropriate mechanical system which would achieve the following requirements for the car park barrier:

Enable parts A and B of the barrier to connect together so that Part B rotates to almost vertical whilst Part A remains horizontal when the barrier rises. To facilitate this Part A and B must be connected to the guide bar shown which is driven by the motor. All connections and bearings must be indicated along with a suitable method of attachment from the guiding bar to the chosen solution.

[6 marks]

(ii) On pro forma answer number **4(d)(ii)** design, draw and annotate an appropriate mechanical system which would achieve the following requirements for a crane stabiliser:

Allow the stabiliser to be raised and lowered using a rotating mechanism as the input. These give the crane stability when lifting a heavy load. The operator should be able to complete this manually and lock the stabiliser at the desired height.

[4 marks]

Section C

Product Design

Answer **both** questions in this section.



Fig. 12

5 Fig. 12 shows a photograph of a shopping trolley.

(a) Some designers may consider a shopping trolley to be an incremental product.

With reference to a different but suitable product of your choice explain what is meant by an incremental product.
[2 marks]

(b) The company designing and manufacturing the shopping trolley has completed a life-cycle assessment. Explain what is meant by a life-cycle assessment.

[2 marks]

(c) Sustainability is an important consideration when designing and manufacturing new products within the shopping trolley market. Designers when selecting a metal for the trolley frame gave careful consideration to responsible sourcing and recycled content.

(i) Outline **two** main reasons why consideration should be given to responsible sourcing when selecting a metal for the trolley frame. [2 marks]

1. _____

2. _____

(ii) Outline **three** main reasons why consideration should be given to the recycled content when selecting a metal for the product. [3 marks]

1. _____

2. _____

3. _____

(d) When designing and manufacturing the shopping trolley, information and communication technology (ICT) was used to assist with quality control (QC) and quality assurance (QA) systems.

(i) For a specific product of your choice describe how ICT is used to assist in the implementation of quality control. [2 marks]

(ii) For a specific product of your choice describe how ICT is used to assist in the implementation of quality assurance. [2 marks]

(e) When planning for the future, the company manufacturing the shopping trolleys considered that it should invest in 3D scanning facilities and adopt a quick response manufacturing (QRM) approach.

(i) Explain **two** benefits of 3D scanning which could be used to persuade the company to invest in the equipment. [4 marks]

1. _____

2. _____

(ii) Explain **two** benefits of QRM which could be used to persuade the company to adopt this approach. [4 marks]

1. _____

2. _____



Fig. 13

(g) With reference to **Fig. 13** above and on the blank A3 pro forma (answer number **5(g)**) use detailed annotated sketches to produce **one** possible solution for the following:

An appropriate design of a bracket which will ensure that the scanner shown in **Fig. 13** is securely housed in an upright position and is firmly attached to the hand rail of the shopping trolley. Your design should allow the user to quickly move the bracket and scanner along the circular shaped hand rail to accommodate left and right-handed people. [10 marks]

6 **Fig. 14** shows photographs of road traffic safety cones. These thermoplastic cones have a reflective sleeve, a hollow profile to allow for stacking and a weighted base to improve their stability.



Fig. 14

(a) The company designing and manufacturing these traffic cones had recently decided to redesign their product range.

Outline **two** main reasons why products are redesigned.
[2 marks]

1. _____

2. _____

(b) In order to expand the business opportunities of the company a marketing strategy proposed a focus on market penetration, product development and diversification.

Outline **two** main characteristics associated with each of the following:

(i) Market penetration [2 marks]

(ii) Product development [2 marks]

(iii) Diversification [2 marks]

(c) Traffic cones like the ones shown in **Fig. 14** on page 46 experience an introduction and growth phase during their product life cycle.

Explain **two** main differences between the main characteristics of introduction and the main characteristics of growth. [2 marks for each]

1. _____

2. _____

(d) When determining a suitable price structure for the traffic cones the company considered the following pricing methods:

- Cost-plus
- Contribution pricing, and
- Perceived value.

With reference to the traffic cone explain the main characteristic associated with each of the following:

(i) Cost-plus [2 marks]

(ii) Contribution pricing [2 marks]

(iii) Perceived value [2 marks]

(e) Many consumers feel that good product design will ultimately ensure that the products we use will have a minimal impact on our environment. With reference to **two** different products briefly explain how the environmental impact of each product has been reduced by the influence of good design. [2 marks for each]

1. _____

2. _____

- (f) The work of the national government can directly or indirectly influence the design of products which in turn can influence key environmental issues.

Outline **two** specific examples of how the national government has influenced the design of products.
[2 marks for each]

Example 1

Example 2

- (g) Products can incorporate moral and/or social factors in their design.

- (i) Describe **one** example of a product which incorporates moral factors in its design. [2 marks]

- (ii) Using a different example describe a product which incorporates social factors in its design. [2 marks]

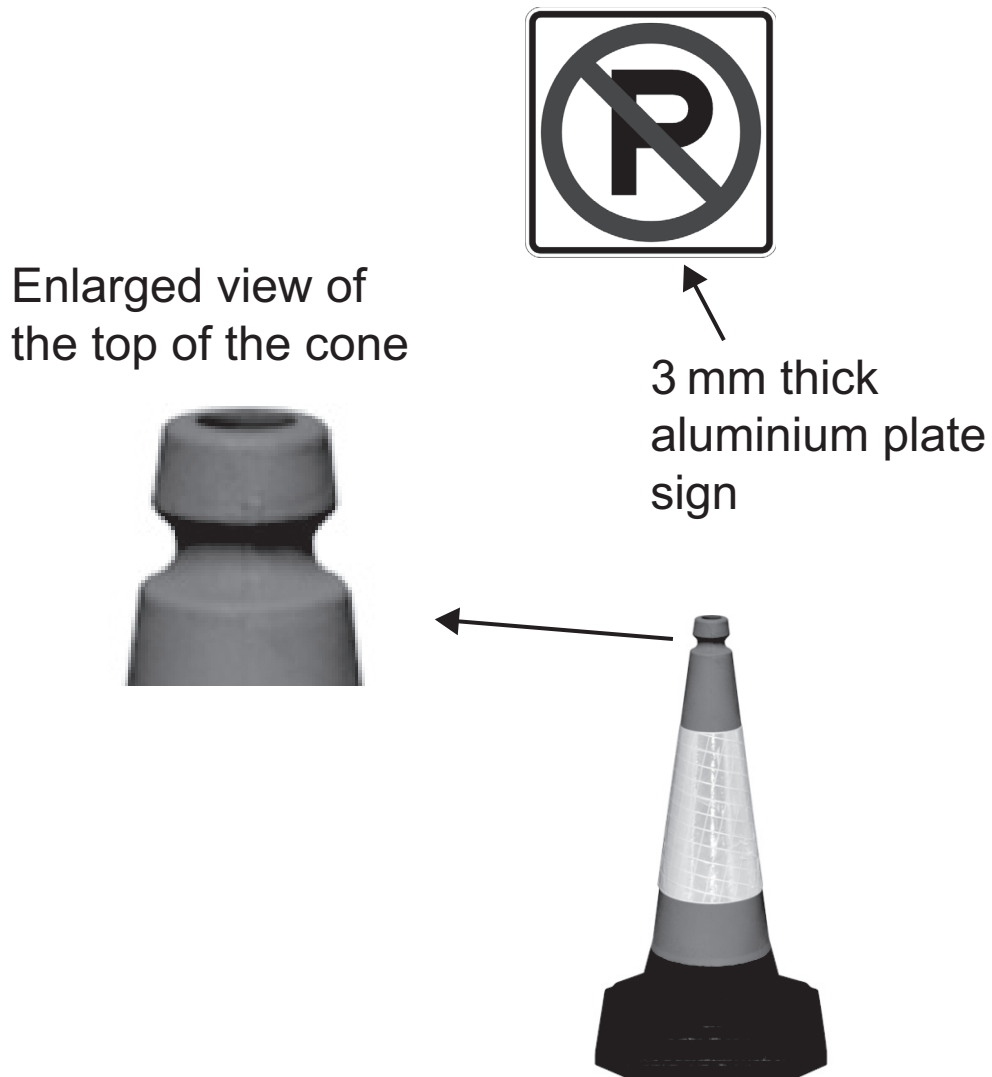

Fig. 15

- (h) (i)** With reference to **Fig. 15** and on the blank A3 pro forma (answer number **6(h)(i) and (ii)**) use detailed annotated sketches to produce **one** possible solution for the following:

An appropriate design that would allow the user to quickly and securely attach or detach the sign shown in **Fig. 15** to the top of the cone without making any modifications to its shape or profile. Your design should ensure that the sign cannot rotate when fixed in position. Show how your design is attached to the back of the 3mm thick aluminium plate sign.

[5 marks]

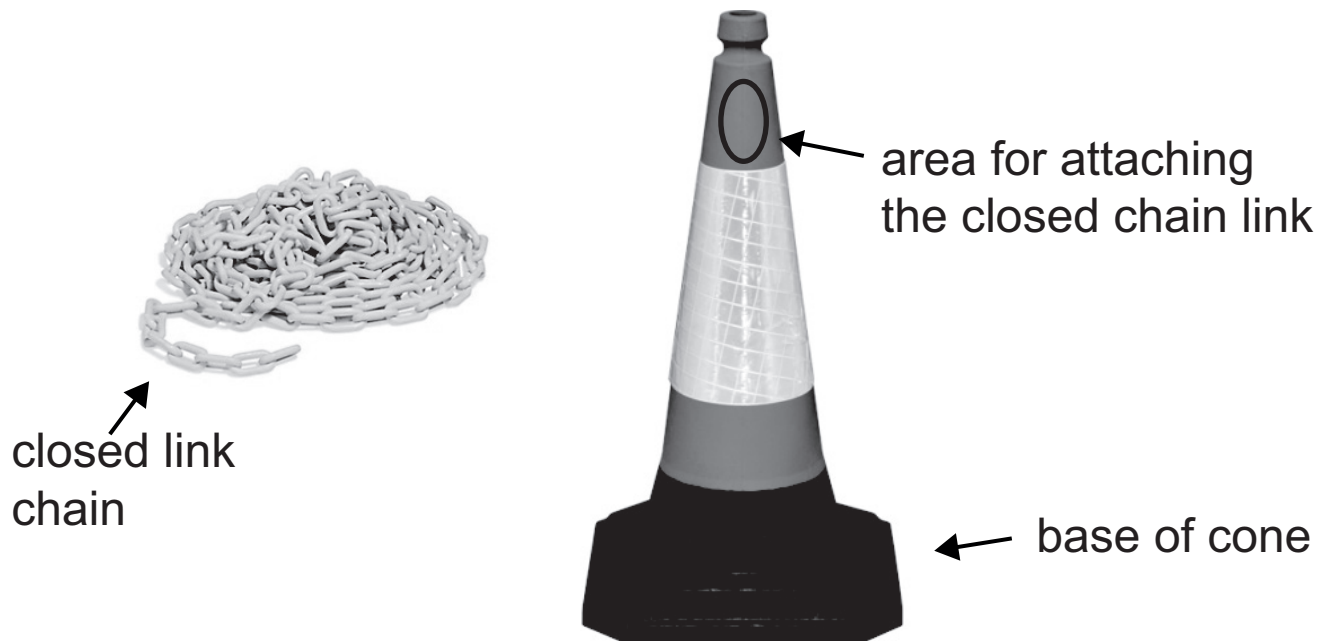

Fig. 16

- (ii) With reference to **Fig. 16** and on the blank A3 pro forma (answer number **6(h)(i) and (ii)**) use detailed annotated sketches to produce one possible solution for the following:

An appropriate design that would allow the user to attach a closed chain link to the road cone at the position shown to increase the range of functions of the product. Explain how your design takes account of the need for large scale production.

[5 marks]

THIS IS THE END OF THE QUESTION PAPER

SOURCES:

- Q1(a) Source: ©CCEA
- Q1(b) Source: ©CCEA
- Q1(c)..... Source: ©CCEA
- Q1(e) Source: ©CCEA
- Q2(a) Source: ©CCEA
- Q2(d) Source: ©CCEA
- Q2(e) Source: Principal Examiner
- Q3(a)(i) ..© roman023 / iStock / Thinkstock
- Q5..... ©ekinyalgin/iStock/Thinkstock
- Q5(g)© jauhari1 / iStock / Thinkstock
© AngellInternet / iStock / Thinkstock
- Q6(a)©oorka/iStock/Thinkstock
- Q6(h)(i) .© Enfield Safety
- Q6(h)(ii) .© Enfield Safety

For Examiner's use only	
Question Number	Marks
1	
2	
3	
4	
5	
6	
Total Marks	

Permission to reproduce all copyright material has been applied for.
In some cases, efforts to contact copyright holders may have been unsuccessful and CCEA will be happy to rectify any omissions of acknowledgement in future if notified.